



PONDLINK®
BY PONDTEAM INTERNATIONAL

Pondlink® Wi-Fi Controlled

Pressure Filter

Instruction Manual Model 20000 and 30000



IMPORTANT: Please read this instruction manual carefully before using this product. Keep the manual safe for future reference.

Manual version - 18.05.2022



Pondlink® Wi-Fi Controlled Pressure Filter

Thank you for purchasing a Pondlink® Wi-Fi Controlled Pressure Filter with the innovative Pondlink® technology. The Pondlink® Wi-Fi Controlled Pressure Filter combines mechanical and biological filtration with a powerful UV clarifier, to create clear, healthy pond water.

Being pressurised, the Pondlink® Wi-Fi Controlled Pressure filter is easy to hide in ground with only the top 20 cm visible. Even a long distance away from the pond, hidden away from view - like at the top of a stream.

Cleaning the Pondlink® Wi-Fi Controlled Pressure filter is easy – in fact fully automatic once set up with the Pondlink App.

Just lean back and enjoy your pond.

As we continually improve and develop our products and mobile App. descriptions, functions, products and accessories etc. may differ from images on the packaging, instructions, user's guide, etc.

We recommend that you check our website for the most up-to-date manuals and information: www.pondlink.com

Table of contents

3. Features, usage and automation	14-15. Setting timers and options
3. What is included	16. Sockets A (pump) and B (other)
4. Safety instructions	17. Other functions
5. Quick-guide to filter placement	18-19. Maintenance (sponges)
6. Quick-guide to how to place the hoses	20. Replacement of UV lamp
7. Bypass connect the pump	21. Seasonal care – Winter etc.
7. Clean to avoid permanent damage	22. Troubleshooting
8. Recommended pump	23. FAQ
9. Manometer	24-25. Exploded view
10. Specifications	26. Guarantee
11. Description	27. Privacy and data protection
12. How the filtration works	28. Storage page
13. Installation	29. Notes
14. Control panel / manual operation	30. Waste, legal and contact
15-16. First time app installation	



Filtration Features

- Mechanical and biological filtration combined.
- Powerful UV clarifier to tackle green water.
- Can be buried in the ground up to its lid.
- Wide inner diameter capable of high flow-through of water.
- Ideal for use with Pondteam® Filtration pumps.

Usage

Only suitable for outside in garden ponds - *not swimming ponds*. UV can be run continuously, 24 hours per day.

- If using 1¼" or 1½" hose, cut off the smaller diameter step(s) on each of the three supplied hoesetails.
- Make sure the clamp ring is secured while the filter is running.
- Always unplug UV before viewing or handling.
- Do not look at UV bulb when lit and plugged in.
- Spend 30 minutes checking for leaks after installing.

How the automation works

The filter can easily be set to an automatic self-cleaning cycle.

Via the Pondlink App you will be able to set:

- Timer for cleaning from once a day to once a week.
- The use of water during the cleaning cycle.
- Program timer for *socket B* to use with Pondlink feeder. (Only connect products that are compatible with the Pondlink filter to socket B).
- We advise *always to use socket A for the pump in pump mode*.
- UV timer.

You will be able to receive reminders and warnings from your filter by e-mail. Everything is easy to set up in the Pondlink App. Please see the *setup* pages.

What is included



- 1 x Pondlink® Wi-Fi Controlled Pressure Filter
- 3 x Hose connectors (for 32/40/50 mm hose)
- 3 x Locking nuts
- 3 x Gasket washers
- 1 x User manual

If, after unpacking the pressure filter, anything is missing or damaged, this should be notified to the dealer immediately.

Safety instructions

1. Electrical installation must be in accordance with local regulation. They should not be placed near the pond – but at least 2 metres away. Make sure that plugs and sockets are always dry.
2. Equipment can only be worked with the socket which has safety earthing protection. The socket must conform to the related national regulations (VDE, ENC.....,IEC...).
3. Make sure the voltage in the name plate is the same as the actual power supply.
4. Ensure that an RCD (of which the rated working current is not over 30mA) is installed when using the filter and connected devices, and the power sockets must be connected to an earth.
5. For your own safety, please contact an electrical professional in case of questions and problems.
6. Do not connect the power supply when parts are not installed.
7. Only operate the equipment if no people in the water.
8. If cable or shell is damaged, please do not use. Place the cable so it is not in the way and not in danger of being damaged. Never lift or carry the pressure filter in the cable and protect the cable against heat, oil and sharp edges.
9. Before any maintenance you should disconnect the power supply and pull out the plug.
10. Before use please ensure that the equipment and connection plugs have not been affected by damp - and are completely dry.
11. Ultraviolet light can cause damage to the eyes and skin. Only switch it on when installed inside filter.
12. Do not insert the plug into the socket until all parts are assembled and mounted.
13. Do not immerse the pressure filter in water.
14. For safety reasons, this equipment should not be used by children and young people under the age of 16, as well as persons who cannot understand the potential danger posed by this equipment. Persons who have not fully understood the following instructions may not use the equipment.
15. Advanced replacement of parts and repairs. This manual contains the regular maintenance instructions. Replacement of valve components and O-rings, and sealing the wet and dry section of the filter must be done by a qualified professional. Only qualified professionals are allowed to replace electric parts.

Quick-guide to how and where to place the filter

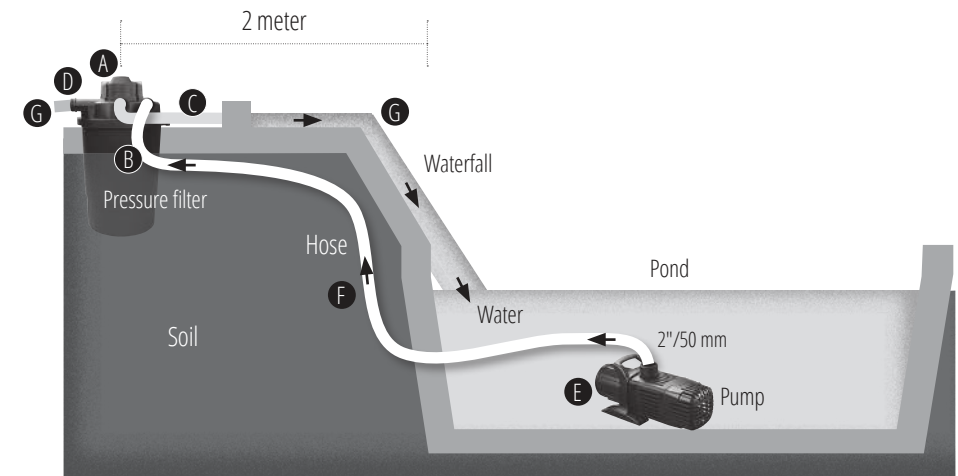

- A. Clean if necessary, but always at least once a year, before winter storage. Dirt that gets stuck here can solidify, causing the valve to break.
- B. Inlet – hose connects from the pump.
- C. Outlet – hose return the water to the pond.
- D. Waste outlet-hose must always have the same diameter as the "Outlet-hose".
- E. The pump must have a maximum lifting capacity of 5 meters. Hose withstands at least 0.2 Bar pressure.
- F. Inlet-hose can have a smaller diameter than the "Outlet-and Waste-hoses. The Inlet-hose should never have a diameter less than 1½".
- G. Waste- and Outlet-hoses must have the same diameter, to avoid to high working pressure. Recommended not less than 2".

- Working pressure should be kept as low as possible and never exceed 0,2 bar
- Damage will occur if exceeding 0,3 bar = 3 m. Head.
- Can have a powerful pump if, for example, you want a larger waterfall, then run water bypass, so some go directly to the waterfall and not through the filter.

Quick-guide to how to place the hoses

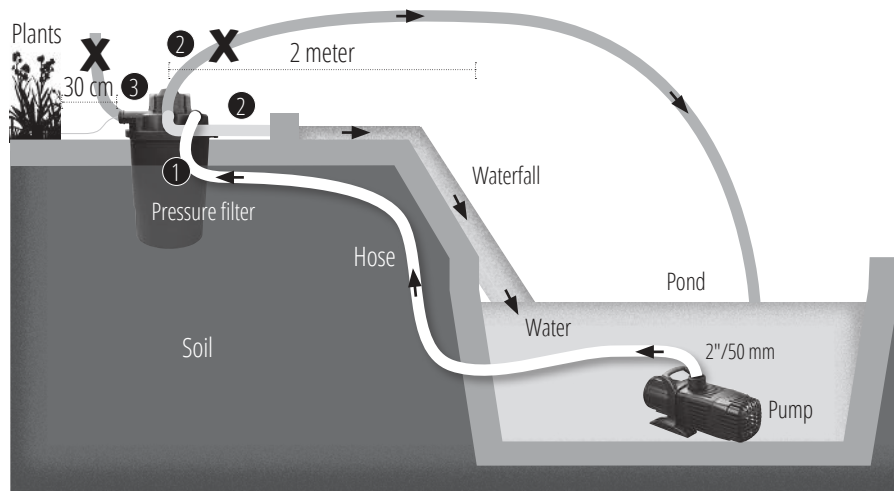

Hoses

Placement and diameter for hoses are important to avoid high pressure in the filter. That can damage the filter.

1. Inlet: The hose to be used, can have a diameter smaller than the "Outlet" and the "Waste outlet". But are recommended to be at least 1½".
2. Outlet: The hose are not supposed to pressure water above its outlet. Recommended 2" hose.
3. Waste outlet: Must NEVER have a diameter smaller than the "Outlet hose". The "Waste-hose" must be placed horizontal from the outlet or lower. Use a maximum 30 cm long hose. Recommended 2" hose.

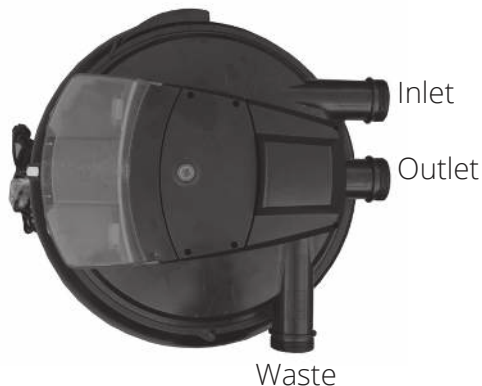

Lid from above

Recommend the same hose diameter for all tree hoseconnections.

Always have the same for "Outlet" and "Waste" hoses, to avoid high pressure in the filter. To high pressure can damage the filter.

Bypass connect the pump

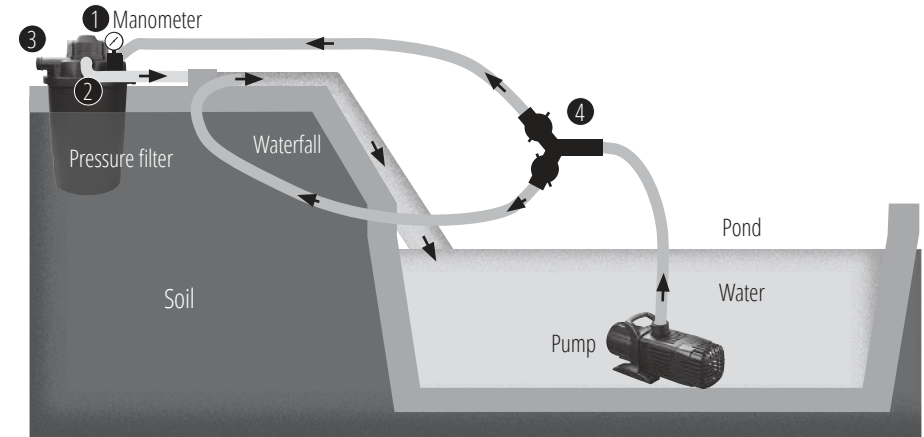

1. Inlet. 2. Outlet. 3. Waste 4. Tree-way valve (place it above or below the water surface, where it is easy to adjust).

Bypass pump to filter and waterfall

3-way / bypass for pumps over:
 Pondlink 20000: 12000 lph / 5 m.
 Pondlink 30000: 15000 lph / 5 m.

Always use Manometer (art.no. 41915) when bypassing.

Can have a powerful pump if, for example, you want a larger waterfall, then run water bypass, so some go directly to the waterfall and not through the filter.



Manometer sparepart, art.no. 41915.

Clean to avoid permanent damage



Look at pages 19 to see how to separate the filter.

It is very important to regularly clean the hose-connections and the Lid. This to avoid that limestone and dirt get stuck there. Which can cause permanent damage to the filter.

Important: Lubricate o-rings during maintenance and start-up of filters.

Recommended pump

Pumps with a larger capacity than those recommended by the filter manufacturer must not be used. The filter **MUST** be cleaned regularly. It must never work with a water pressure higher than 0.2 Bar = 2 meters lifting height. A higher working pressure in the filter can cause O-rings to not hold tightly and consequential damage occurs such as, that the dam is emptied of water. The maximum pressure capacity of the pump must not exceed 0.5 Bar (5 meters lifting height).

Only use hoses that are approved for a pressure of at least 0.2 Bar. The height difference between the filter cover and the highest point of the outlet hose may be a maximum of 1 m. Check and, if necessary, clean the filter outlet to the dam regularly. The outlet must always be free so that the filter does not risk being exposed to a pressure higher than 0.2 Bar. This can cause the filter to start leaking and emptying the dam.



Manometer

(Art. No. 41915 - buys as an accessory). Good complement to mount on the Pondlink filters. The manometer is mounted on the filter inlet. Via the Manometer, the working pressure of the filter can be easily read in BAR. By avoiding excessive pressure in the filter, unnecessary leakage and consequential damage, which is caused due to excessive pressure in the filter.

Any attempt to tamper with or access electrical components inside the filter body is dangerous and will invalidate the warranty.

Specifications

Technical data	20000	30000
Product nr.:	40920	40930
Filter volume:	ca. 50 l.	75 l.
Max pond size without fish:	20000 l.	30000 l.
Max pond size with goldfish:	10000 l.	15000 l.
Max pond size with Koi:	5000 l.	7500 l.
In/Out (Thread/hose) :	2"/32/40/50 mm	2"/32/40/50 mm
Recommended flow:	12000 lph	15000 lph
UV-C PL:	36 watt	55 watt
Voltage:	230V 50 Hz	230V 50 Hz
Size (mm):	450 x 450 x 550mm	450 x 450 x 715mm

Max combined load socket A+B = 800 watt

Working pressure should be kept as low as possible and never exceed 0,2 bar

Damage will occur if exceeding 0,3 bar = 3 m. Head.

Description



The Pondlink® Wi-Fi Controlled Pressure Filter is a unique automatic pressure filter, which can be connected to Wi-Fi and controlled via an app. It is a pressure filter with built-in UV-C device for biological and mechanical filtration of normal pond water with a temperature between +4°C and + 35°C. This pressure filter is intended for private use only, for cleaning of ponds with or without fish. Be sure that the equipment will only be used in accordance with the technical data. Do not use the filter in liquids other than water. The filter may not be activated if there is no water running through the System.

The filter has several features that makes it easier to get an advanced and clear pond. The Pondlink-system is connected with your broadband via Wi-Fi at the 2.4 Ghz band. you can download the app for iPhone or Android. (Search for Pondlink).

Using the app, you can easily monitor and automate your pond:

1. Set to Automatic backwash.
The pressure filter will do a backwash with pre-determined time intervals or you can start a backwash when you want to, directly from the phone.
2. Monitor that the UV-C lamp works and how long burning time it has had.
Can also be set by a timer.
3. There are two power contacts with a timer function on the filter. The pump must be connected to Contact A, so the pump can be monitored and an automatic water saving program can be used during the backwash.
4. You can receive an alert by email if an error occurs, or confirmation when the filter has finished the backwash.
5. There will be new features through software updates.
6. The filter can of course also do backwash manually by pressing the touch button on the filter.

The function of the filter gives you one of the most efficient filter systems available, and it has several different filter systems built in.

The Pondlink® Wi-Fi Controlled Pressure Filter does not need a prefilter.

1. Filter sponges with different pore sizes for both oxygen-consuming and non-oxygen-consuming bacteria. Both nitrites and nitrates are degraded.
2. Bioballs at the bottom with large surface for useful bacteria to purify the water biological.
3. Comes with a powerful UV-C unit with a stainless-steel UV-housing, which increases the radiation up to 30%. No more green water.

How the filtration works

A. Inlet

Dirty water from the pond pump (not included) passes via a hose through the inlet into filter.

B. Vortex system

Under the action of gravity, suspended solids and mud are separated.

C. Mechanical filter

When the water passes through the filter sponges into the internal chamber, dirt particles will be caught on the first part of the surface of the sponges.

D. Biological filtration

The pores of the filter sponge creates a large inner surface which microorganisms can colonize. The yellow and blue filter sponges differ in size and density. This creates zones in which the water can flow at different speeds. Zones with a high flow speed (blue filter sponges) allow the colonization of microorganisms which convert ammonium to nitrate via nitrite (nitrification). Zones with a low flow speed (yellow sponges) support the colonization of anaerobic micro-organisms which reduce nitrate to nitrogen (denitrification).

E. UV-C radiation for clear water

Water is finally passing by a special UV-C lamp, covered by a quartz-sleeve in a stainless tube, exposing the water to UV-C radiation and sterilising algae.

F. Water outlet

At the water outlet, the clarified water is fed back into the garden pond via a hose, watercourse or stream.

G. Waste water outlet

During the cleaning process the dirty water is separated and passes through the drain outlet. This can be used to fertilize your garden plants.

H. Rotating cleaning shaft for automatic cleaning

The filter sponges are compressed and scratched on the surface removing dirt and old bacteria. At the same time waterflow is reversed by the cleaning valve (behind A+F) removing the dirt via the outlet G.

I. Control panel

Led indicators and touch buttons for manual operation and Wi-Fi setup.

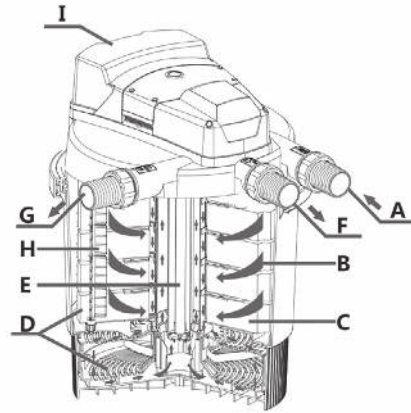

Installation

1. Filter should be installed with a min. distance to the pond of 2 m. on a stable base or in ground with the top 20 cm. above - to allow access to open the lid clamp. Make sure that the filter and sockets cannot be flooded in case of heavy rain or low placement.
2. When installing, please make sure the filter is placed where Wi-Fi signal can be received well. Avoid covering or shielding filter with metal objects as this will affect Wi-Fi signals.

TIP If Wi-Fi signal is too weak a simple mobile hotspot can be placed in your garden shed.

3. Avoid direct sunlight.
4. The operation of this filter requires a pump (to be purchased separately). Use hose with as large diameter as possible and never use a smaller hose for the outlet than the inlet. Do not block outlet (F) or waste water outlet (G) with valves - working pressure inside the filter should not exceed 0.3 bar.
5. The pump must be connected to the filter via socket A. The maximum combined power consumption of both socket A and B should not exceed 800 watt, and only pond related equipment should be connected.
6. The pressure of the hose (to be purchased separately) connecting the filter with the pump should not be less than 0.3bar.
7. This filter can be connected to the hose with inner diameter of 1¼", 1½" or 2".
8. Please choose large diameter hose to reduce the loss of the flow of the pump.
9. This device is equipped with 2 intelligent sockets, in which the A socket is a special outlet for the supporting pump. B socket can be connected to any other Pondlink related equipment.
10. Before putting the system into operation, first connect the pump and check whether there is water leakage in the connection between the hose and inlet/outlet. Then check the functions and monitor the filter for 30 min.

Control panel and manual operation

5. Touch Button "Wi-Fi / UV - Double Function

This button is used to set Wi-Fi connection / Enable use with mobile app at long press. See fig. 6.
At short press, it turns on and off for the filter's UV-C light. The light can be seen through the small transparent glass on top of the UV-C unit.

2. Wi-Fi LED indicator

Flashes slowly without connection, quickly upon activation (Button 5 Wi-Fi / UV) - and steady light when the filter is connected to the Wi-Fi network.

3. Clean LED indicator

Flashing during the cleaning process that is activated by pressing "Button 8.Clean" – or via App.

1. Socket A LED indicator

Lights up when socket A (pump) is switched on which is one by pressing "6. Socket A " - or via App.

4. Socket B LED indicator:

Lights up when socket B is activated, which is done by pressing "7. Socket B "- or via App.

6. Touch Button "Socket A"

Switch on/off socket A (Pump Controller). LED Indicator 1. lights up when it is on.

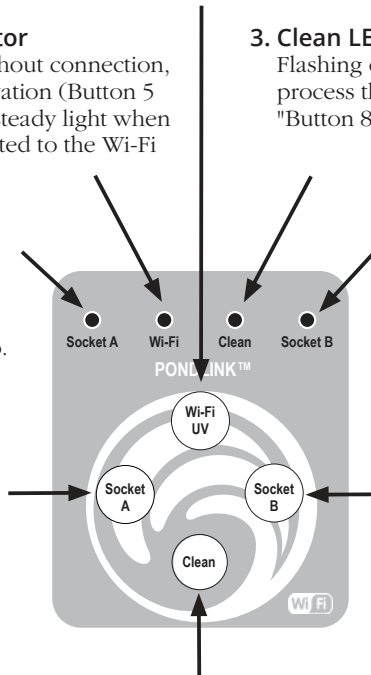

7. Touch Button "Socket B"

Switch on/off socket B. LED Indicator 4. lights up when it is on. Timer set in App.

8. Touch Button "Clean"

Pressing starts cleaning cycle. Duration can be set in App. LED Indicator 3. flashes during the cleaning process.

By installing our App according to the following pages, you agree to our terms of use.

You can read more about our terms and conditions and protection of your personal information on our website www.pondlink.com.

First time installation of App



1. Search and download the App "Pondlink" from App store / Google play and install.

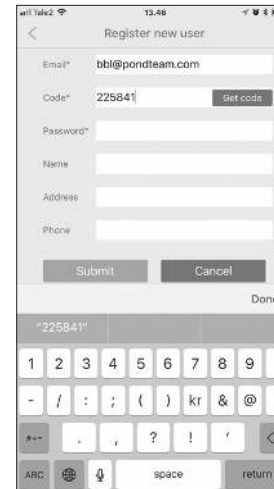

4. After a few minutes the code should appear in your mailbox. Type this and password and press "Submit".

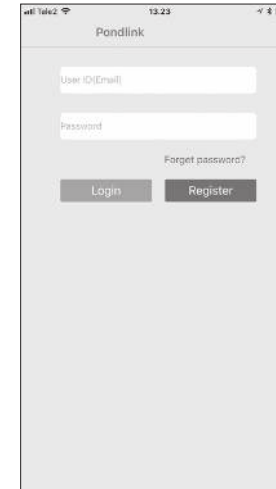

2. First time you open the App you will have to register as a minimum your email and a password. Press "Register".

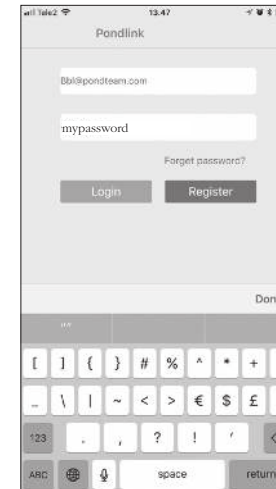

5. Back in the login screen. Fill in your e-mail and password (will be stored on your mobile) and press "Login".

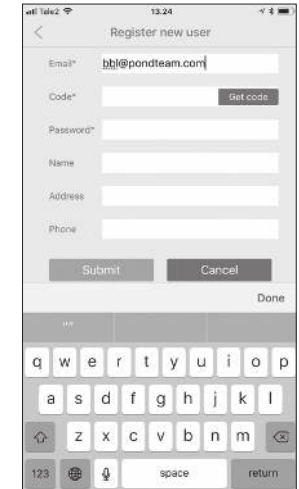

3. Fill in your e-mail and password (optional other details) and press "Get code".

6. Power on your filter if not already done.

Wi-Fi LED indicator (2 from left) should flash slow.

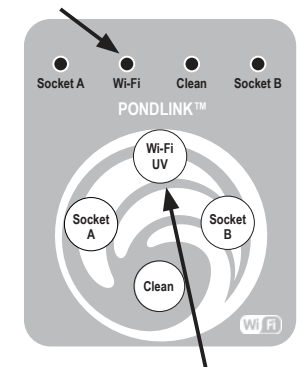

Press and hold Wi-Fi button for 5 sec. until LED is flashing fast.

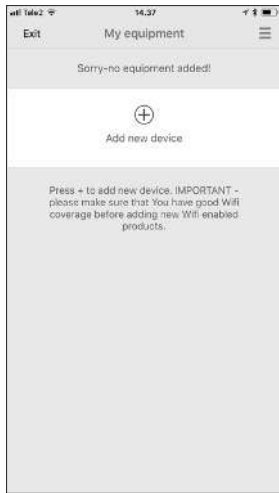

7. Locate the serial no. on the label over the cable on your filter and Press "+" to connect to filter.



8. Fill in your serial no. and press "Link".

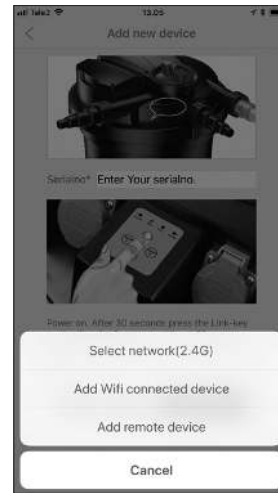

9. Select network (2.4G).



10. Fill in the password for your Wi-Fi network (selected by your Wi-Fi setting in your mobile phone). Press "Search".

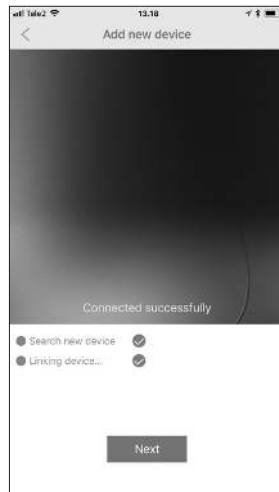

11. If your network signal is ok and 2.4 Ghz., Wi-Fi LED will change to steady light. After connecting ok - Press "Next".

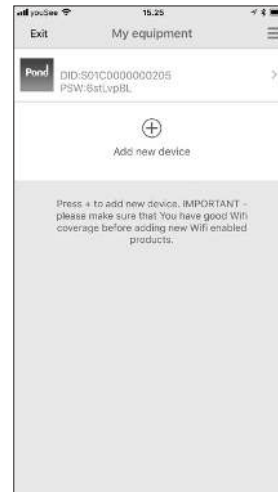

12. Your filter will now appear in the list with serial no. and hardware password. Press to see filter details.

Setting timers and options



13. You see temperature and manage settings here. First option is setting for the automatic cleaning function.

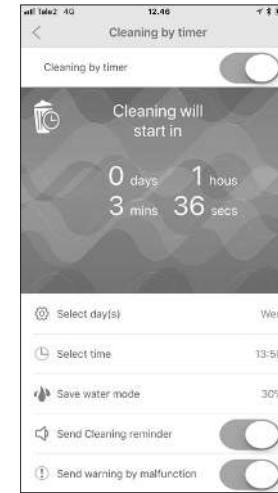

14. Here it is counting down to next cleaning and options to set timer, water-saving, and e-mail alerts.

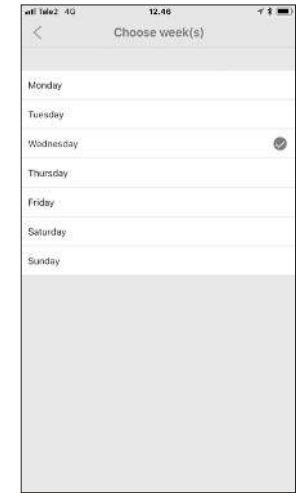

15. Timer can be set from once a week to once a day. A good option if you need to combine with waterchange.

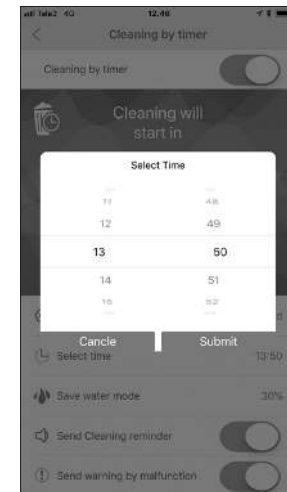

16. Time. We recommend that you set a time, when you are normally at home if you want to verify and adjust settings.

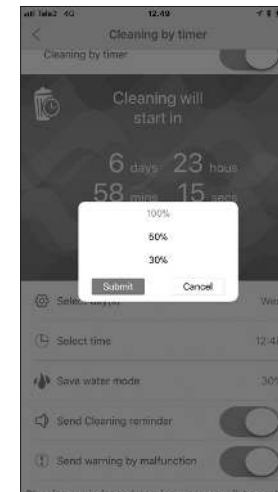

17. Use only 30% or 50% water for cleaning by turning the pump in Socket A off and on during the process.

18. Alerts
We have built in extra smart functions in your Pondlink filter.

If a serious malfunction is detected there will be an acoustic alarm sounding from the filter.

Email alerts and notifications. By enabling the email alerts you will receive a mail if the filter detect a malfunction.

Enabling notifications will keep you informed when the cleaning process starts, if network connection is lost and other useful information.



19. You can also activate an extra manual cleaning process at any time to check function or for extra maintenance.

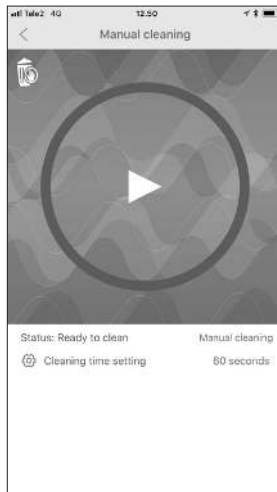

20. Press ">" to start the cleaning process. Further you can set the time for the process from 60-300 seconds.

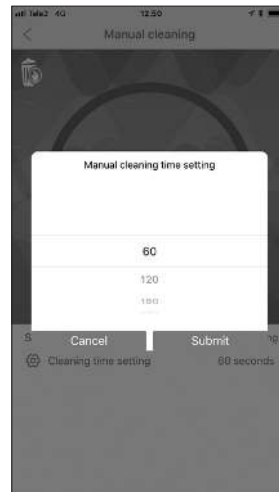

21. The time adjustment gives you the option to adjust to the best cleaning process depending on your pond conditions.



22. The UV menu also gives you a lot of options and information.

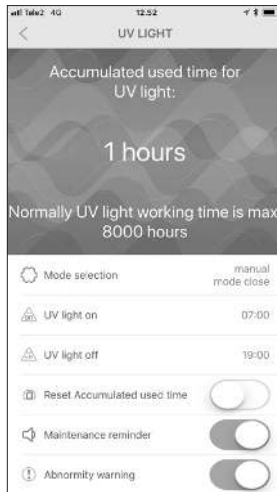

23. Accumulated time indicate time for change, Timer, Reset time when replacing bulb and get alerts and notifications.

24. UV settings and alerts
Mode selection for on/off
Timer:
During pond season the UV should run 24/7. But to adapt to your pond size and seasonal changes, you can set the timer.
Reset time when replacing UV-C bulb. Recommended every spring for best effect.
Enabling notifications will keep you informed about required change.
If a serious malfunction is detected an email alert will be sent if enabled.

Sockets A for pump and B for other pond-equipment



25. Socket A is reserved for the pump supplying the filter! Assuring safety and functions. Max. 800W total on both A+B

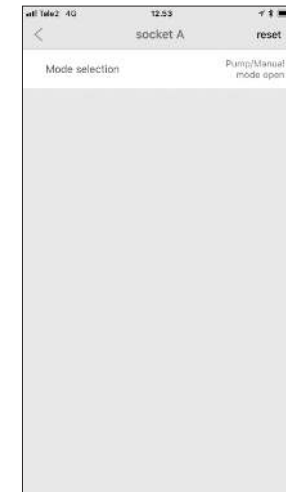

26. *Keep In Pump mode* where other functions are locked preventing mistakes ...



27. Other options can be enabled, but we *do not* recommend that this socket is used for anything else than the pump.



28. Socket B can be used for all pond-equipment like feeder, dosage pump, light etc. Max. 800W total on both A+B

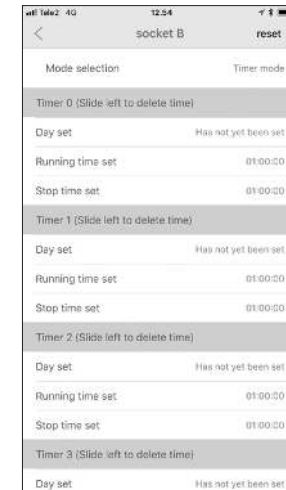

29. Precise timer-setting for feeders and dosage pumps.

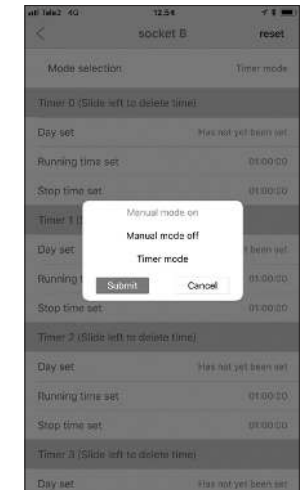

30. Further to timer setting remote on/off function supported.

Other functions / change serialno. / install options



31. Enable extra functions in upper right corner.

32. Check and install firm-ware updates for Wi-Fi connection.

Delete present Pondlink device from App.

A reinstallation will reset all functions if system should ever lock up.

Change filter password for security and privacy:

A. Delete filter (as fig.31) (or swipe left as fig.33)

B. Power off at least 15 sec. and perform a new first time installation as per fig. 6. The new password will appear under the serial no. as fig. 12.

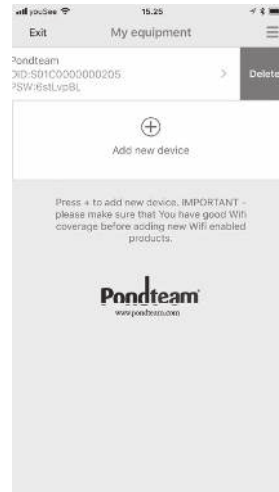

33. Installed Pondlink devices can also be deleted by swiping left and pressing "Delete"

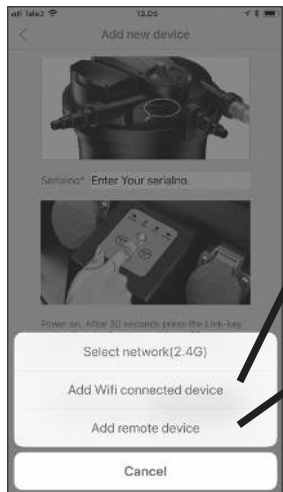

34. You have 2 other options to add already installed filters to your App.

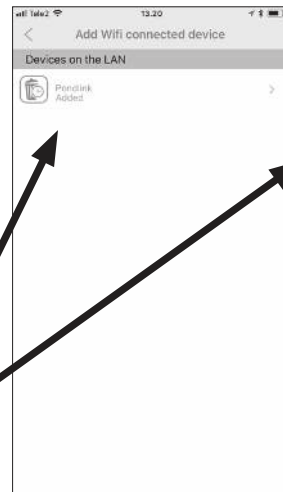

35. Press to install a *filter al- ready connected to the local Wi-Fi network* (Wi-Fi LED on fixed green light - fig. 6).

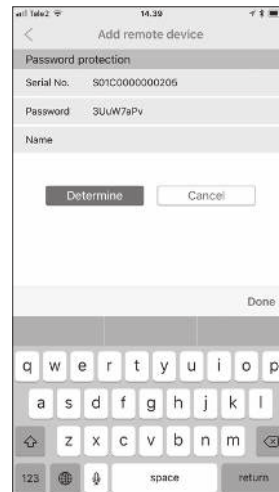

36. Press to install *remote filter*. Allow installers and others to operate your filter. Filter-name can be specified.

Check/Cleaning/Replacing the filter sponges

After 1-2 seasons or when the water flow is reduced – and it does not help to clean using the automatic cleaning function. The sponges should be checked/manually washed or replaced. Do not use any kind of detergent as this will kill the microorganisms in the sponges. Over winter the filter should also be cleaned and have a service check before storing indoor for winter – please see seasonal care.



Turn off the filter and disconnect the power cord from the switch.



Step 1 Remove the protective cap and then open the large clamp on the canister.



Step 2 Slowly lift up the filter cover with the filter sponges, and leave it on the canister until the water is completely drained away from the sponges. Place It horizontal on its side – do not place it upside down with the lid at the bottom.



Step 3 The base plate can now be gently released from the centre column (UV part) by turning the UV-bottom shield.

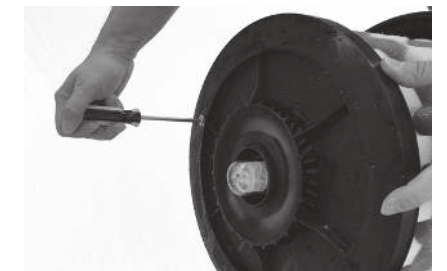

Step 4 Using a screwdriver (not supplied) - unscrew and remove the washer and screw.

Filter maintenance *(continued)*



Step 5 Please take care not to loose the plastic bearing on the foam side of the plate when removing the base plate.

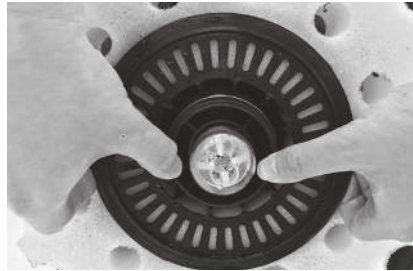

Step 6 Now the filter sponges can be removed. The plastic holders in the middle of the sponges are easy to remove. Carefully dismount the small connections that hold the parts together.

Step 7 The filter sponges are best rinsed in a bucket of pond water or luke warm tap water. Squeeze the sponge firmly together several times until the water that is pressed out is clean. Clean the container, filter holders, O-ring and the edge of the container by sprinkling them with a hose.

The plastic holders are then refitted to the sponges and mounted in the same order as before the cleaning. Fit the filter sponges so that they fill the entire space between the top and lower base plate.

The base plate can then be remounted into place with UV-bottom shield, bearing, washer and screw.



Step 8 Fit the O-ring in place on the top of the cannister (to facilitate the placement of the lid, you can use silicone grease (preferred) or make the O-ring wet. The lid can then be pressed in place and the large clamp be mounted from the hinge side and locked.



Step 9 Now refit all the hoses again – remember to insert the flat gaskets and tighten the locking nuts. After turning your filter on again, you should observe it for 30 min. to ensure everything is working fine.

Replacement of UV lamp

Ensure power is switched off and power cord of filter unplugged.



Step 1 Unscrew the four screws under the rubber plugs on the lid of the UV-unit.



Step 2 Pull up the UV-unit by pressing with your thumbs on the lid and lifting with all other fingers below the unit.



Step 3 Clean the quartz glass tube with a wet cloth and dry.



Step 4 Remove the fixing-nut on the quartz glass tube.



Step 5 Pull out the quartz glass tube - then you can pull out and replace the UV lamp.



Step 6 - Check the quartz glass tube and change it if broken. Ensure all o-rings are in place and greased with silicone grease.

Assemble all part of the filter as before and start up the filter again.

Seasonal care - required precautions

Take care of - and prevent the following conditions

Frost

The filter must be dismantled when frost is foreseen at the latest at +4°C.

Clean the filter and take the opportunity to grease and replace O-rings and UV-bulb – this will keep your filter in good condition for many years.

Service kit is available from your vendor, and most can also perform the service for you against a fee.

In winter, store the filter in a well ventilated and frost free location and leave an airpump running for your fish in the pond if deep enough.

Please note that any damage relating to improper overwintering of the filter will void the warranty.

For complete separation of the lid – the Rotating wing shaft can be dismantled by unscrewing it from the top after the sponges are removed (steps 5 and 6 on page 17). This is also useful when delivering the top to a retailer for service / maintenance.



Very high humidity

Make sure that the filter is always placed in well ventilated places regardless in use or not. In rare occasions high humidity in combination with shifting temperatures may result in damp damaging sockets and electronics.

This is not covered by the warranty.

Extensive sunlight

High temperatures may damage your filter – so make sure that it is not exposed to direct sunlight.

Trouble shooting

1. If water is leaking around the hoses, check that the supplied rubber washers have been fitted. Check that the hose is the right size for the hose tail and that the hose clip has been properly tightened.
2. If water is leaking from the clamp, check that it is done up properly and tight, and that the O-ring is present inside the filter casing.
3. If the water turns green, check that the UV is running 24 hours per day. If more than six months old the lamp will need replacing. Check that the quartz sleeve is clean and clear, to allow the UV light to penetrate the water. Check that the pump and filter have been properly matched for the pond size.
4. If filter sponges are difficult to clean or worn out, replace old sponges for new.
5. **Water is slowly dripping from the waste outlet during normal operation?**
Try to run a cleaning cycle a couple of times. If this does not solve the problem the rubber seals in the valve should be replaced. This should be done by a qualified professional, as this requires the o-rings between the wet and dry section of the filter to be opened.
6. Wi-Fi installation

I see 2 equal names for my Wi-Fi connections?

If you have a Wi-Fi router supporting more than one frequency with the same name.

Tip is to name multiband network including the Frequency – like “Mynetwork-2.4” and Mynetwork-5”

I can install but not connect to the filter?

Tip. If you have previously connected to the 5 GHz network, your mobile might automatically switch to this during setup.

So the best thing to do is to delete (forget) this network-connection in your mobile before making a new installation via the 2,4 GHz connection.

After making sure that you can only connect to the 2,4 GHz network. POWER OFF your filter FOR ATLEAST 15 SECONDS before restarting installation. You will find more information at www.pondlink.com

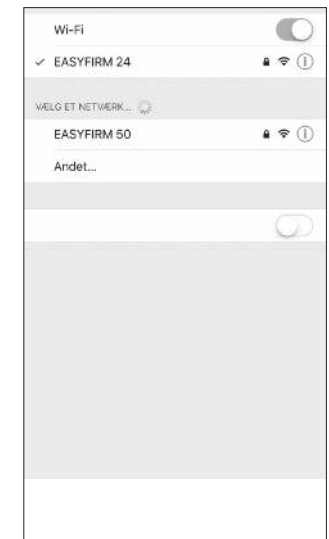

FAQ

Can others connect to my filter?

Once installed and locked to your local Wi-Fi network and your mobile – you (and only you – unless you have allowed others to make an equal local installation) can access your filter from any network connection.

You can allow remote connection by providing your serial no. and filter password to others.

How do I change the password for my filter?

Filter password is automatic changed by pressing the Wi-Fi button for 5 seconds and reinstalling the filter. Delete the filter by swiping left before reinstalling.

Can my pond be emptied if valve is not working or power fails?

If you make sure that your pump is connected to Socket A, you will have the following safety:

- Power supply is cut off at the same time as filter in case of power failure.
- Pump will be turned off during valve operation and not switched on again before valve contact is locked in position.

Do I need to buy a new pump to use the filter?

No – most pumps with a max. flow of 20000 l./h. and a max. power consumption of 400 watt will work with the filter. Please note that on rare occasion some electronic pumps requiring very stable powersupply might react unpredictably on electronic and frequent power on/off.

Where can I find the mobile App?

The mobile App is available for IOS® and Android® – current version can be downloaded from App Store and Google Play – search for "Pondlink".

Exploded view

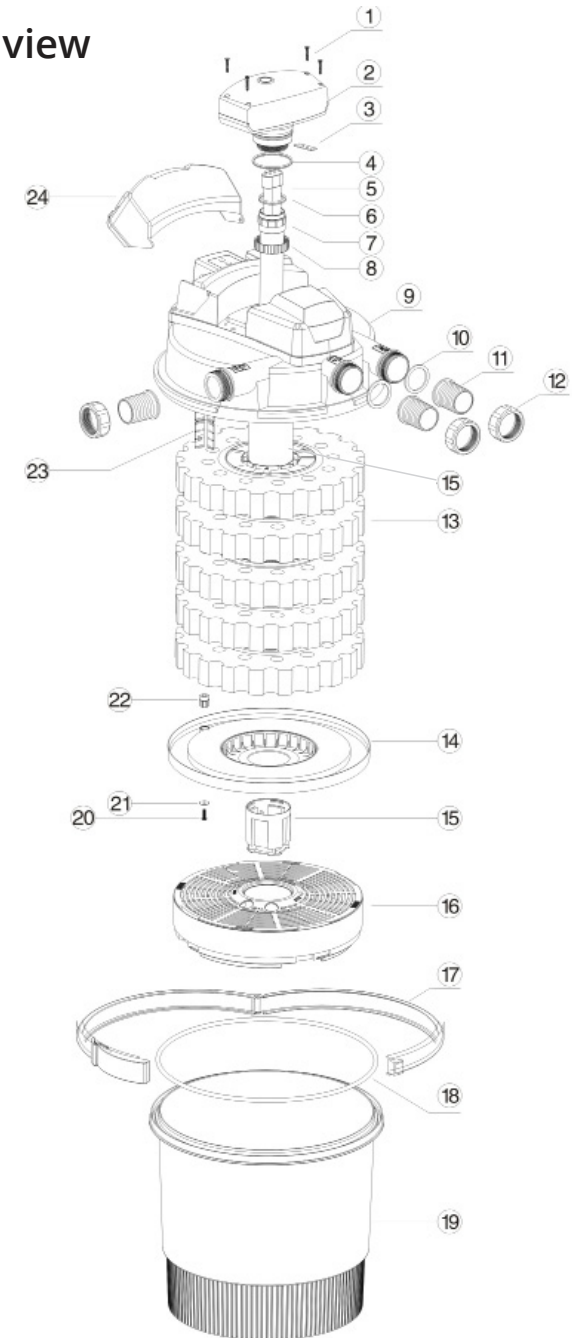

		20000	30000	Common ist white
1	Screws	41952	41962	
2	UV-ballast	41952	41962	
3	Square Rubber gasket			
4	Double O-ring ballast	40807	40807	
5	UV-C Lamp	40416	40417	
6	Double O-ring quartz	40807	40807	
7	Quartz glass set	41951	40797	
8	Quartz glass locking nut			
9	Filter lid			
10	Seal gasket	41904	41904	
11	Hose connector	41904	41904	
12	Locking nut	41904	41904	
13	Sponge set fine (Y) and coarse (B)	41929	40714	
14	Base plate			
15	UV-C shield set	41953	41964	
16	Biological media cassette			
17	Lid clamp	40856	40856	
18	Lid o-ring	40713	40713	
19	Filter cannister	40865	40854	
20	Screw for wing shaft	41927	41927	
21	Washer for wing shaft	41927	41927	
22	Bearing for wing shaft	41927	41927	
23	Rotating wing shaft	41928	41948	
24	Lid for control panel and sockets			

**ALL WEARING PARTS AVAILABLE FROM YOUR RETAILER:
UV-lamp, quartz glass tube, filter sponges, O-ring set etc.**

Guarantee

This product is guaranteed against defects in material and workmanship for *two years* from the date of purchase, under normal usage.

The guarantee *Does not apply* in case of improper use, negligence, lack of maintenance or accidental damage to the filter. If the filter fails due to a manufacturing fault within this period it will be either repaired or replaced free of charge. Moving parts or wearable parts including UV-lamp, quartz glass tube, filter sponges, O-ring set, Valve gaskets etc. are not covered by the guarantee and are available to order from your Pondlink® retailer.

Should your Pondlink® product stop working refer first to trouble shooting and if this does not help, please contact your Pondlink® retailer. If still unsolved – please return the product to the place of purchase in a clean condition.

Liability is limited to replacement of the faulty product only. No other costs will be reimbursed. This guarantee is not transferable and does not affect your statutory rights.

Do not attempt to tamper with or access electrical components inside the filter body. Doing so will invalidate the warranty.

The manufacturer or supplier shall not be responsible, or held liable for any damages caused by defective components or materials of this product, or for loss incurred by interruption of service, or any consequential/ incidental damages and expenses arising from the production, sale use or misuse of this product or any other consequential loss.

Any warranty claim must be accompanied by a valid, dated proof of purchase. Pondteam International AB, its distributors and dealers shall not be held liable for any loss of fish, plants or any other livestock as a result of any failure or defect of this product.

The installation and use of your product outside of our recommendations as printed in this manual may also void the warranty.

Pondlink® Wi-Fi Controlled

Pressure Filter

Instruction Manual



www.pondlink.com

Pondteam International AB

Mossvagen 17 - 23237 Arlov - Sweden

www.pondteam.com

Copyright Pondteam International AB - 18.05.2022

Pondlink® and Pondteam® are registered trademarks. Other trademarks used in this manual, on our website or in our catalogues are the property of their respective owners. We reserve the right to change specifications of products, App's and recommendations without notice.

Pondlink® filters are protected internationally by registered design and patents – further patents pending.



Waste management

A defect UV-C unit/lid must Not be thrown in the normal municipal waste, but must be delivered at one of the home municipality's recycling stations.